

## The role of the tropane skeleton in drug research

Laszlo Gyermek, MD, PhD.

Professor of Anesthesiology (Ret). University of California at Los Angeles, Harbor-UCLA Campus, and Los Angeles Biomedical Research Institute, Torrance, California.

This review describes certain reminiscences about an area of chemical pharmacology I have been involved with, on and off, for many years. Specifically it focuses on tropane, a fascinating, naturally occurring bicyclic chemical ring system that lends itself to many pharmaceutical and therapeutic applications. My involvement with the tropane ring has started more than 60 years ago in 1949, when, as a young assistant in the Institute of Pharmacology at the Medical Faculty of the University of Budapest, I started out to probe into some, yet unexplored chemical pharmacological aspects of the best known tropane alkaloid, atropine; which is the tropic acid ester of tropine, the simplest, naturally occurring tropane compound, the structure of which is shown in Figure 1.

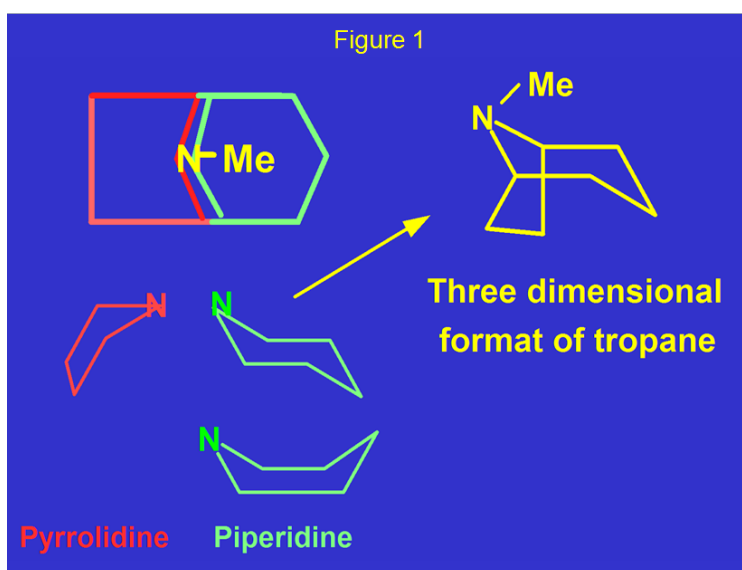

The bicyclic ring system of tropane can be construed as a condensation product of a piperidine and pyrrolidine ring with a shared N atom as shown in Figure 2. Figure 3 calls attention to the numbering of the atoms of the tropane ring. Thus the exact chemical name of tropane is: 8 Methyl azabicyclo (3.2.1) octane. This name also characterizes the manner how this bicyclic ring system is branched, which has distinct pharmacological significance.

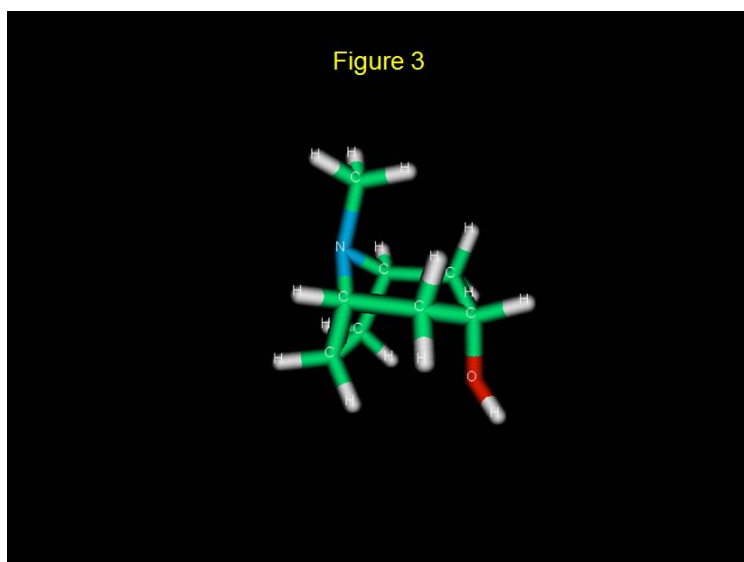

There exist about 230 naturally occurring tropane derivatives (1). The number of synthetically produced tropane compounds is, however much higher, and amounts to the thousands. As mentioned, tropine (or tropane 3 alpha- ol) with a molecular weight of 141 and a molecular volume of 142 cubic Angstrom is the smallest tropane alkaloid, while the largest is grahamine, a trimer, with three fused tropane rings, with a molecular weight of 860 and a molecular volume more than five times that of tropine (Figure 4). The largest number of tropane alkaloids are substituted on the carbon atom 3 of the tropane ring and usually occur in the form of tropine esters. (Figure 5). However, there exist a fair number of natural tropane derivatives, which contain their mostly ester components attached also to the 2, 6 and/ or the 7 carbon atoms of the ring (Figures 6 and 7).

Figure 4

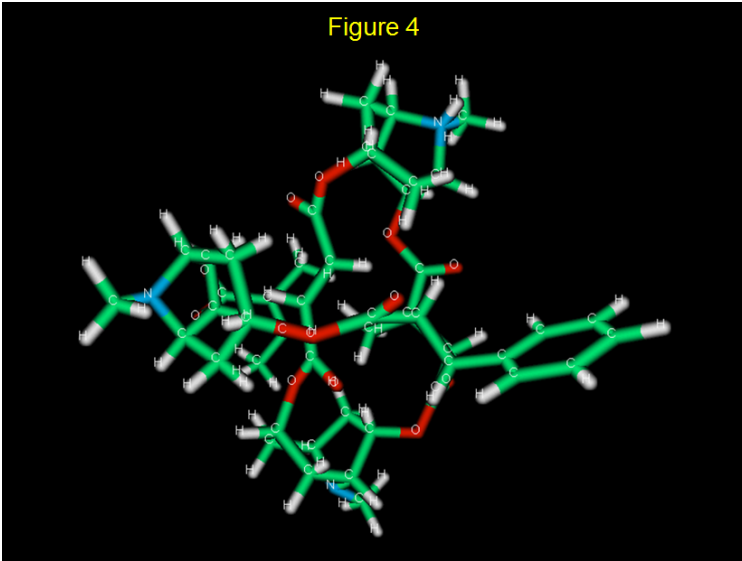

Figure 5

Substituents on the tropane ring  
of tropane alkaloids.

Substitutions on the C<sub>3</sub> atom:

when **R= OH** → Tropine / ψ-Tropine

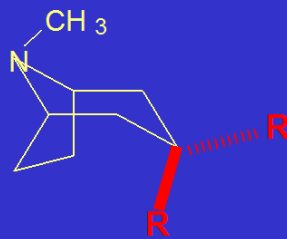
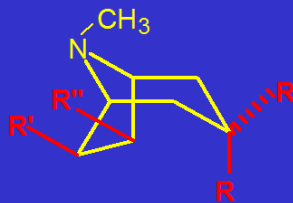

Figure 6

Substituents on the tropane ring of tropane alkaloids  
Substitutions on the C<sub>3</sub>, C<sub>6</sub> and C<sub>7</sub> atoms:



when R, R' and R'' are usually OH or Acyloxy  
( The 6 and 7 OH groups can form epoxy bridge  
e.g in Scopolamine )

Figure 7

Substituents on the tropane ring of tropane alkaloids  
Multiple substitutions  
(e.g. on C<sub>1,2,3</sub> or on C<sub>1,2,3,4</sub> and on C<sub>1,2,3,6</sub>)

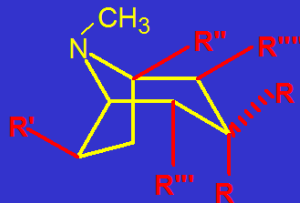

when R, R', R'' and /or R'''' are usually  
OH (or Acyloxy )

The pharmacologically most important tropane alkaloids are atropine, scopolamine and cocaine. All of them are aromatic acid esters of tropine. Atropine is the dl-tropic acid ester of tropine, scopolamine is the l (-) tropic acid ester of scopine, which is 6-7 (exo)epoxy tropine (Figure 8), and cocaine is the benzoic acid ester of pseudo ecgonine, which is 2-carboxy tropane 3-beta-ol (Figure 9).

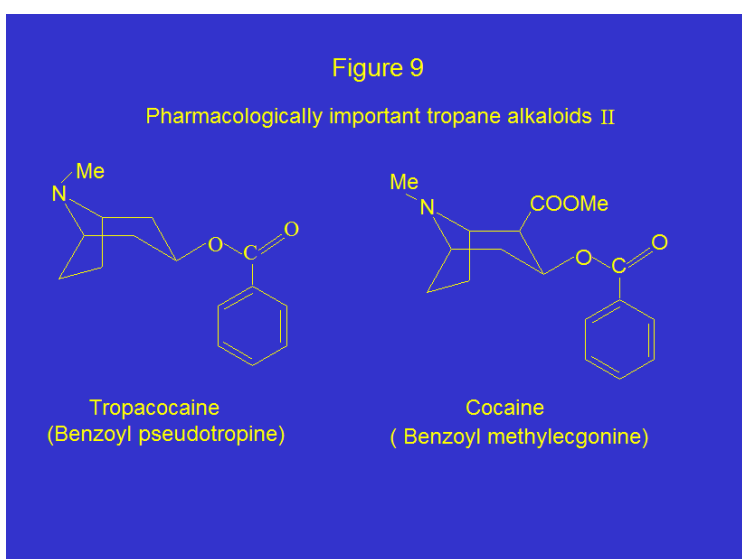
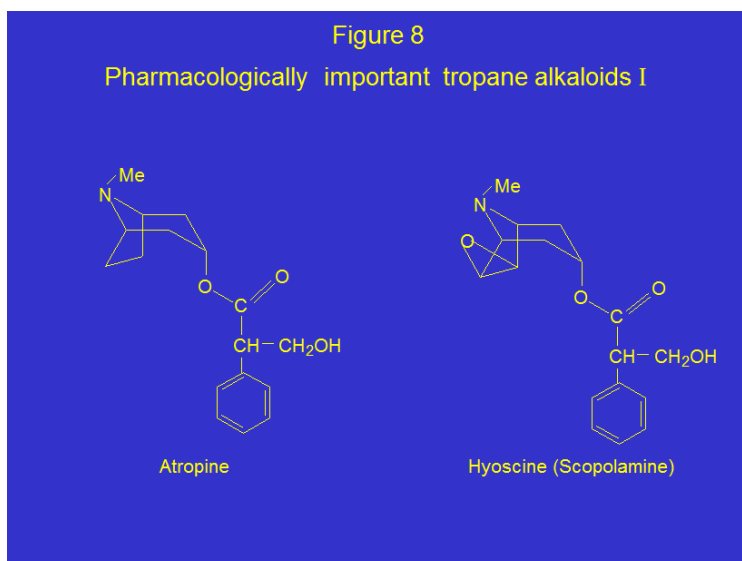

Since the best recognized pharmacological actions of tropane derivatives are related in the body to the functions of the neurotransmitter acetylcholine (ACh), at this point it is appropriate to refer to few, historically significant discoveries related to the pharmacology of ACh. ACh displays two different types of actions mediated by its receptors in the peripheral nervous system. These are recognized as “muscarine-like” and “nicotine-like”. This congenial, but by now simplistic characterization, is a century old and is attributed to Sir Henry Dale (2) (Figures 10,11,12). The number of those, so called cholinergic receptors, at which ACh is recognized to act has been largely extended in the past few decades. Yet their, up to presently preserved basic division still identifies them as “muscarinic” and “nicotinic” receptor types. Turning back to the large family of tropane derivatives one has to

recognize their natural sources, those species of the flora which can synthesize them. These belong to the groups of potato and tomato like plants, namely the Solanaceae, among which the Datura, Belladonna and Hyoscyamus families are the sources of atropine and scopolamine, while the phylogenetically different tropical shrubs of the coca species can synthesize cocaine. The biosynthesis of

Figure 10 ACTIONS OF ACETYLCHOLINE	Figure 11 Dale's tools	Figure 12 Dale's conclusion:
<ul style="list-style-type: none"> <li>• MUSCARINIC</li> <li>• NICOTINIC</li> <li>• (Sir Henry Dale 1912. Amazing insight, but obvious shortcomings in tool selection)</li> </ul>	<ol style="list-style-type: none"> <li>1) <b>ATROPINE</b> (blocked those actions of Ach which were mimicked by <b>MUSCARINE</b>)</li> <li>2) <b>NICOTINE</b> (blocked those actions of Ach which were unaffected by Atropine)</li> </ol>	<p>There are: a) "muscarinic" and b) "nicotinic" receptors for Ach in the peripheral nervous system</p>

tropine consists of 8-10 steps and is illustrated in Figure 13. The laboratory synthesis of tropine is considerably simpler. The first and elegant synthesis of tropine, developed by Robinson in 1917 (3), consists only of two steps: 1) the condensation reaction, employing succinedialdehyde, acetonedicarboxylic acid and methylamine, which yields tropane-3 one, e.g. tropinone (Figure 14), and 2) the reduction of this ketone, either to 3- alpha or 3- beta tropine.

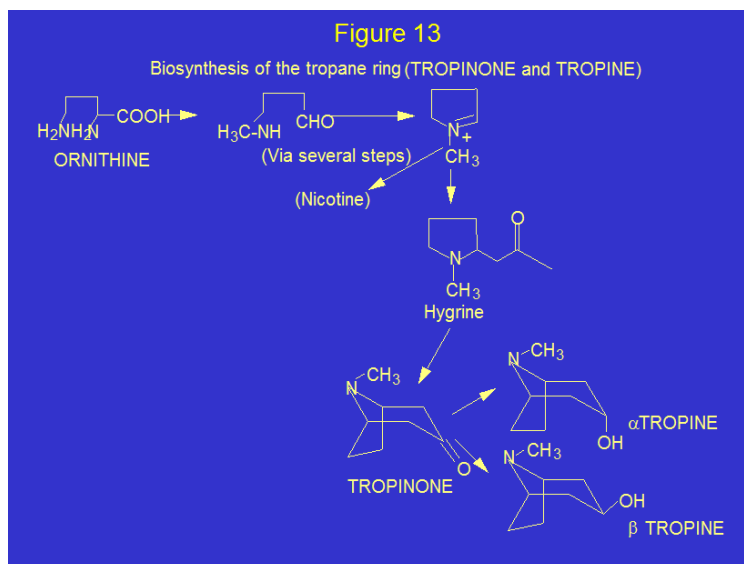

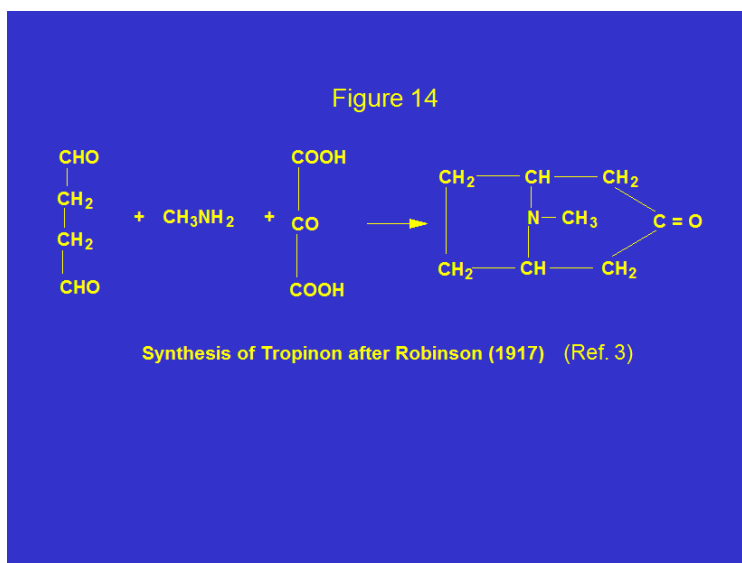

One reason why I started my career in pharmacology with tropane alkaloids and their derivatives has been that Hungarian chemists and pharmacologists have been intensively involved in their synthesis, chemical analysis and pharmacological investigation. While Fodor and Nador reported in 1952 the correct steric configuration of tropine, identifying the chair conformation of its piperidine component and the axial orientation of the N-methyl group, Fodor and his coworkers reported the first total synthesis of scopolamine. Subsequently Nador and his colleagues clarified the different steric configurations about various quaternary tropanium stereoisomers. My pharmacology professor and mentor, Bela v. Issekutz has already discovered in 1917 that by methyl quaternization the anticholinergic, e.g. anti-ACh potency of homatropine has been markedly enhanced, particularly on the gastrointestinal tract (4). This observation has led to the therapeutic application of this quaternary ammonium derivative under the name of Novatropine. Besides an increased antimuscarinic potency, the methylquaternaries of both atropine and homatropine also have shown an increased potency against the ACh – mediated effects on the nicotinic receptors at the motor end plates of the striated muscles as shown by Hildebrandt in 1907 (5) and by Issekutz in 1917, respectively. It took almost half a century to shed further light on the so called anti-nicotinic effects of additional atropine derivatives. First came, a landmark observation from Kimura, Unna and Pfeiffer in 1949, at the University of Illinois in Chicago (6). They, following the example of decamethonium (e.g. 1,10 decamethylene bis trimethylammonium) which has been reported simultaneously in 1948 by Barlow and Ing (7) and by Paton and Zaimis (8) in England as having very strong neuromuscular blocking properties, have synthesized the first bis-quaternary derivatives of atropine. With N, N' 1,10

decamethylene bis atropinium (9) (Figure 15), they described an agent which has been the first, potent bis tropinium type non- depolarizing neuromuscular blocking agent, surpassing tubocurarine in potency. Becoming aware of these observations Issekutz and Nador started a research program for further tropane type neuromuscular blocking agents. I have joined their institute in 1949 and first engaged myself in the exploration of another possible and yet unexplored peripheral anti-nicotinic property, assumed to occur at the autonomic ganglia by these agents. I posed the following obvious questions first: 1) Does the methyl quaternary atropine display autonomic ganglion blocking property and to what extent and 2) What part of that molecule might be responsible for such action (as compared with its other peripheral anti-cholinergic actions). Soon we could establish that in that respect N- methylatropinium bromide has been over ten times more potent than the tertiary amine alkaloid. It was about equal in potency with the prototype ganglionic blocking agent: hexamethonium, in inhibiting autonomic ganglionic transmission in the cat (10). (Further, we could clarify that for such blocking action of methylatropinium, the tropic acid ester component was not necessary, and that this pharmacological property resides mainly with the N- protonated species of the tropane ring itself (11). We have also established that for an optimal and relatively selective ganglionic blocking action the introduction of para substituted aromatic, (e.g. benzyl), quaternizing groups were essential (12). This discovery partly evolved by accident. The case was the pharmacological evaluation of a new batch of N-147, a bis quaternary tropine diester, previously shown to have strong neuromuscular blocking property. Of that agent I was given a new sample for study. N-147 was synthesized through connecting two molecules of benzoyltropine through coupling with one mol. p-xylylene dibromide, forming the desired N, N', bis p-xylylene benzoyltropinium dibromide. Accidentally the new sample became contaminated with a sizeable portion of the monoquaternary species, p-phenylbenzyl-benzoyltropinium.



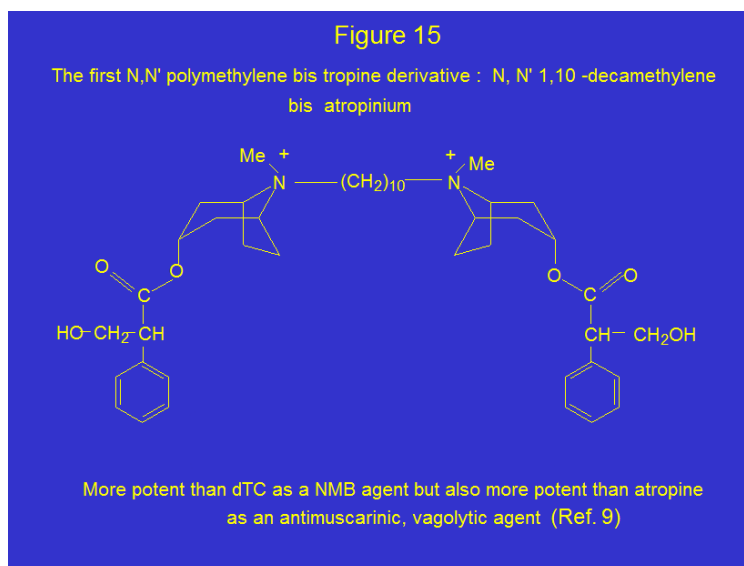

In these early times we conducted most of our pharmacological studies on anesthetized, whole animals, in this case cats, where we had the opportunity to simultaneously observe different, relevant pharmacological parameters, such as neuromuscular block, effects on the arterial blood pressure, heart rate, influence on the cardiac vagal function and also the effect on the transmission through the superior cervical sympathetic ganglion. The new sample of N-147, in contrast to the previous ones, has shown an immense blood pressure drop, heart rate changes and inhibition of transmission through both the cardiac parasympathetic synapses and the sympathetic ganglia. This information called our attention to the high potency of the contaminating component: the para -substituted benzyl quaternary species, indicating the necessity to further explore the role of different substitutions on the aralkyl quaternizing moiety. Accordingly, a few p -phenylbenzyl quaternary ammonium tropane- and tropinester derivatives emerged, which proved to be so far the most potent autonomic ganglion blocking agents known (Figure16) (13).

Figure 16

Structural components for optimal ganglionic blocking potency

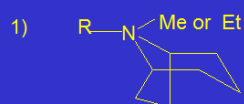

- 2) Where R = para substituted benzyl group  
where R' is Phenyl, Halo- or Me  
or R= longer alkyl, e.g. n-octyl group



In the 1950s research for autonomic ganglion blocking agents was intensively pursued because applying pharmacologic blockade of sympathetic ganglia seemed to be promising in the symptomatic treatment of high blood pressure and the inhibition of parasympathetic ganglia offered a lead towards new anti-secretory and spasmolytic agents of the gastrointestinal and urinary tract. My extensive, early exposure to a large number of quaternary ammonium –type tropane derivatives enabled me, only after I have left Hungary, to publish in 1957 with Nador the first review about the correlations between stereo structure and pharmacological activity of tropane derivatives (13). A decade later, on the request of the recognized pioneer of Medicinal chemistry, Alfred Burger, I have completed a detailed survey on the structure- activity aspects of agents acting on the autonomic ganglia (14). In this review I have paid special attention to two tropane derivatives. The first was N-399, the para phenylbenzyl quaternary derivative of atropine that we described in 1957 (Figure 17) and which shared both potent antimuscarinic and autonomic ganglion blocking properties (15). Under the name

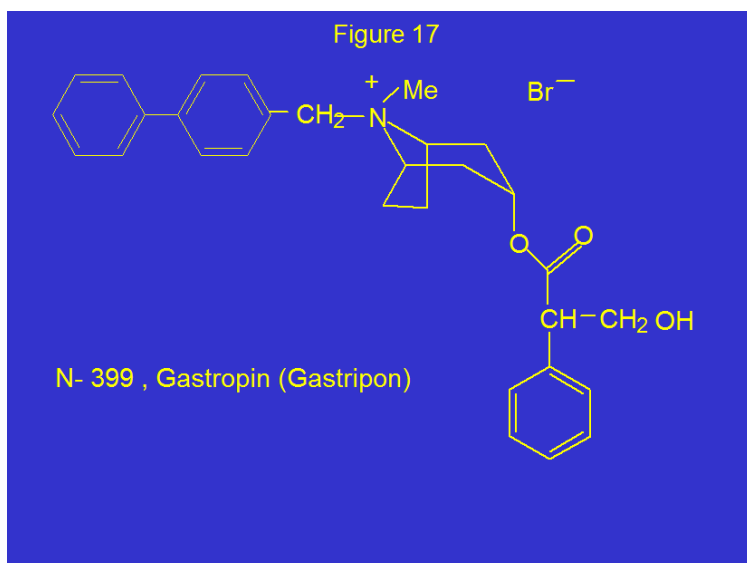

of Gastripon (Xenytropinium, Merck Index) it has been used clinically for several years as a spasmolytic and antisecretory agent. Another pharmacologically unique early tropane derivative has been N-417. p- phenylbenzyl p-aminobenzoyl tropinium. The unique property of this agent was its intensive, nicotine like ganglionic stimulant action. This was so pronounced that it surpassed that of nicotine by a factor of 15-60, dependent on the pharmacologic test preparation used (16). A limited volume structure–activity study has shown that both the para-positioned amino group on the benzoic acid component and the p-phenylbenzyl quaternizing group were essential for this action, along with the tropane ring, which, when replaced by either 2,6 dimethyl piperidine or other simpler alicyclic or aliphatic amines diminished or eliminated the ganglionic stimulant property (16). Until the discovery of Epibatidine some 30 years later (43), N-417 remained the most potent, nicotinic type ganglionic stimulant agent. Unfortunately the molecular pharmacologic mechanism of action of N-417 has not been adequately explored. Structurally this compound is quite different from the best recognized

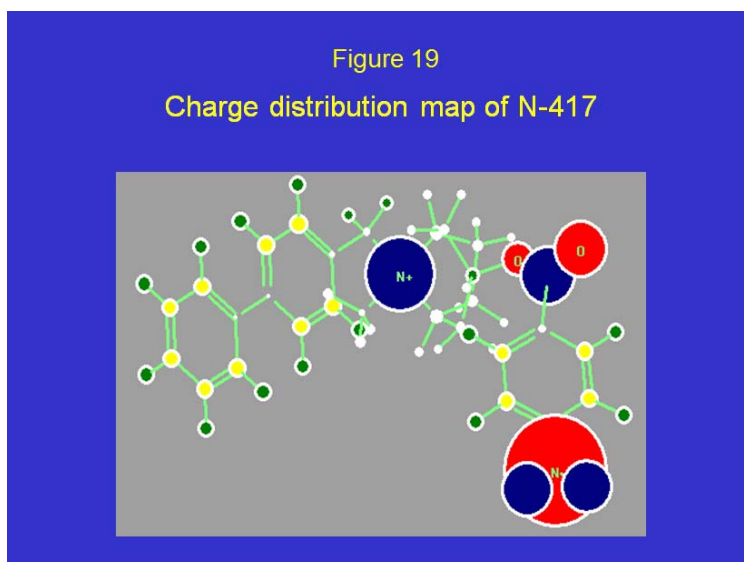
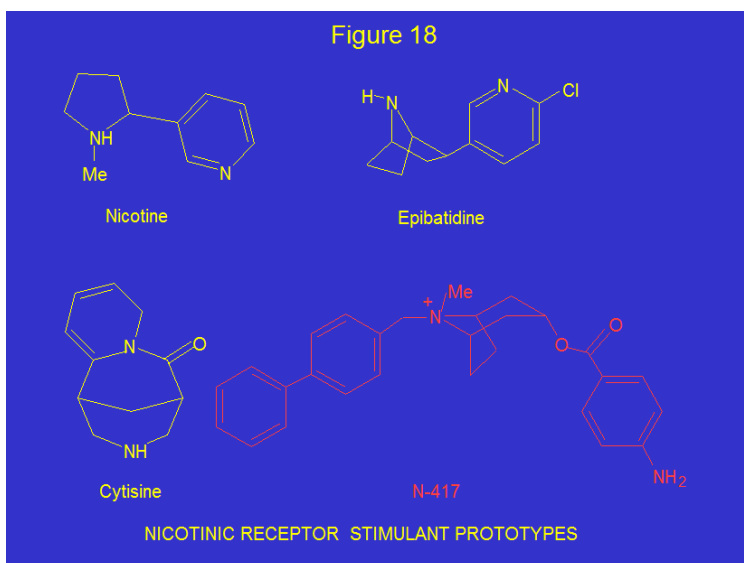

nicotinic receptor stimulant agents (Figure 18). In its mechanism of action the role of charge distribution characteristics around its protonated tropane N atom in relation to its para amino group on the benzoic acid ester seems to offer a possible explanation (Figure 19). Nevertheless, neither the overall shape, nor the functional group distances, as they occur in such prototypical nicotinic agonists as nicotine, cytisine, epibatidine and its derivatives were applicable to this unique quaternary tropane ester (Figures 18 and 20). Of course it has to be taken into account that the old pharmacological data about this agent, deriving from peripheral functional responses, could not be directly assigned to one of the presently recognized nicotinic receptor subtypes. In this context it has to be realized that in the recent decades the molecular biology of fast ion channels-linked receptors markedly progressed. This

happened primarily through the isolation and structural characterization of the nicotinic ACh receptors present uniquely in the electric organ of the sting rays, *Torpedo marmorata* and *californica* where an impressively high density of nicotinic receptors occurs (17). These are of the so called “neuromuscular” type and consist of five transmembrane subunits which form a rosette shaped structure around an ion channel, in this case one, which in its open state allows the exchange of primarily small cations such as sodium and potassium. The vertical view of the rosette shaped receptor-ion channel complex is shown in Figure 21. The amino acid composition and sequence of each trans membrane unit consisting of approximately 30 amino acids each and of attached extra and intracellular loops is of course variable among the different nicotinic receptor subtypes. This can be best illustrated schematically by the vertical view of the receptor complex viewed from above, i.e. from the extra cellular side. Accordingly there exist the heteromeric two alpha, one beta, one delta and one epsilon subunit - containing neuromuscular type nicotinic receptors, characteristic for the electric organ of the *Torpedo* eels. In the central nervous system the predominant nicotinic receptor types consist primarily of heteromeric, alpha 4 and beta 2 type and of the homomeric alpha 7 type subunits. Finally in the autonomic ganglia predominantly, but not exclusively, alpha 3 and beta 4 subunit- type receptors are found (18) (Figure 21). Binding of the neurotransmitter substance, ACh takes place at the adjoining portions of the transmembrane units. In the case of the neuromuscular nicotinic receptor two such regions exist one between an alpha and a delta subunit and another which

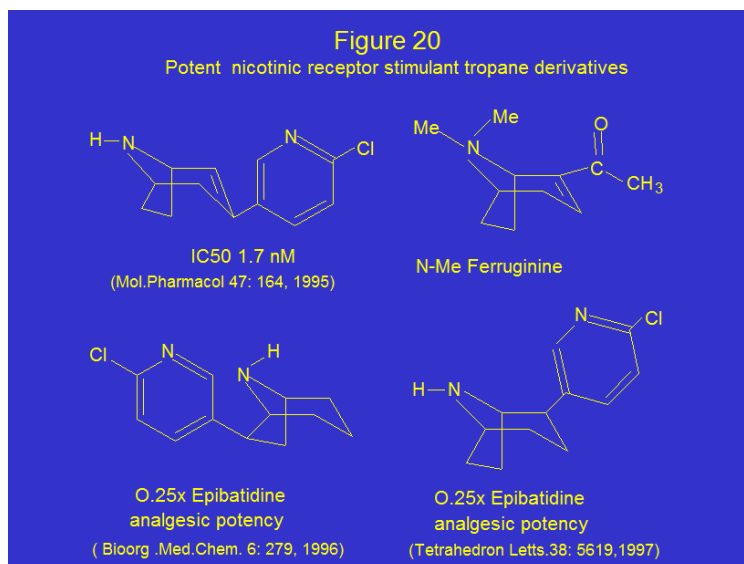

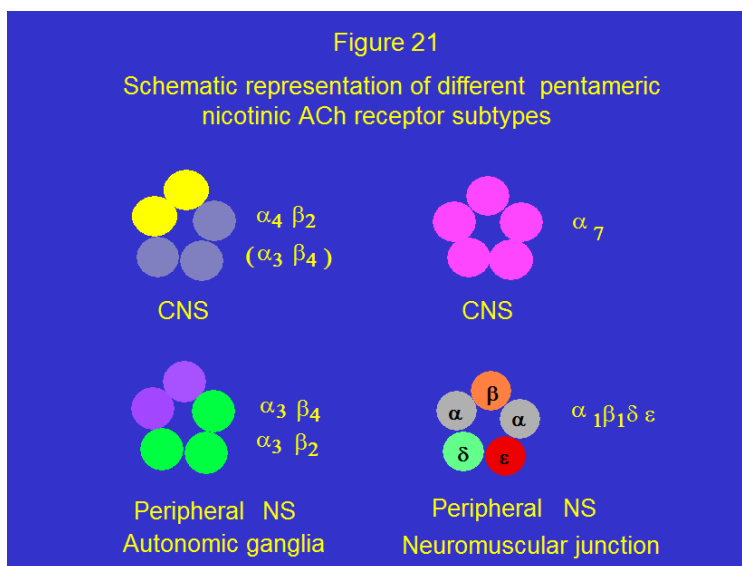

lies between a second alpha and an epsilon subunit. Binding occurs primarily through the polarized atoms of certain, favorably positioned aromatic amino acids, such as tyrosine and tryptophane and an intracellular cystein-cystein loop-part of the receptor. In addition to and in conjunction with the recent discoveries and characterization of different nicotinic receptor subtypes the chemistry and molecular pharmacology of the best known nicotinic receptor ligands has also advanced (18, 19). Primarily nicotine itself, cytisine and epibatidine were those, high affinity agonist ligands which were investigated. However, beyond these the structure and activity features of such agents as muscarone, dimethylphenyl piperazinium, anatoxine, ferruginine and lobeline received attention. It should be noted that in the structure of these latter alkaloids and epibatidine also some structural features seem to be similar to those tropane compounds which possess high affinity to some nicotinic receptors. Yet most in the hitherto published large number of new nicotinic receptor ligands that were synthesized in recent years as pharmacologic probes, aiming either at further exploration of receptor subtype characterization or at the practical goal of arriving to therapeutically applicable new drugs affecting such neuropathologic diseases as Alzheimer's and Parkinsonism and some other central and peripheral nervous disorders, tropane compounds seemed to escape attention (18). Exception has been Cocaine and many of its new derivatives that received considerable interest (20). These molecules however were not approached in depth from the direction of their potential effects on nicotinic receptors. Their exploration so far has been almost exclusively focused on their affinity and efficacy to Dopamine, Norepinephrine and Serotonin receptors- mediated mechanisms (20). As mentioned before, the molecular pharmacology of the old, fascinating nicotinic agent: N-417 has not

been adequately explored. I myself after many years have re-started a small volume research project with ligand binding experiments employing <sup>3</sup>H labeled epibatidine and <sup>3</sup>H labeled cytisine exploring N-417 and few of its derivatives as displacing agents. These experiments after an early stage had to be stopped some 10 years ago, but preliminary results indicated a nanomolar-range affinity of some of these agents, particularly to torpedo-, and to a lesser extent, to brain membrane – nicotinic receptors binding probes and binding site models for the central nicotinic receptor types. As mentioned the structure of N-417 does not fit into any one of the proposed receptor –binding molecular model- geometrics. In the lack of definitive receptor-kinetic data with N-417 and like agents I allow myself just to speculate that there might be a problem with the molecular mechanism of action of this agent in that it may not be a conventionally defined, true nicotinic receptor ligand/ stimulant. By saying this I mean that it may act by a mechanism producing symptoms of postganglionic stimulation through the release of a transmitter other than ACh whose end – organ responses in functional tests may have remained indistinguishable from those of a "true nicotinic receptor stimulant". A second possibility, not completely unlike the previous assumption may be that the molecular models constructed through the adoption of few selected nicotinic ligand prototypes as reliable "templates" are at fault on the account of the still incomplete degree of submolecular, (e.g. atomic) resolution –power of presently available technologies.

With these speculative remarks I would like to close the story of N-417 in the hope that a re-kindled interest in this or similar tropane like molecules, using the latest technologies will be fruitful to further elucidate the peripheral and central nicotinic receptor subtypes and their functions.

*Derivatives of Scopolamine.* The number of derivatives of scopolamine, as compared to that of atropine, remains negligible. In view of our early observations, which indicated that the potency of few quaternary derivatives of scopolamine on the ganglionic and neuromuscular, peripheral nicotinic ACh receptors was inferior to those of atropine we did not pay much attention to such derivatives. The Boehringer Company in Ingelheim, Germany already some fifty years ago experimented in details with the n-butylquaternary derivative of scopolamine that subsequently has been marketed under the name of Buscopan, as a primarily antimuscarinic-type anticholinergic, spasmolytic agent (21), yet with an additional autonomic ganglionic action –component that has been less pronounced than with Xenyltropinium (e.g. Gastripon ). It is noteworthy that both Buscopan and Gastripon

showed a pharmacokinetic component with significant therapeutic potential, due to a higher lipophilicity than with the previously known methyl quaternary anticholinergic agents. Thus a certain degree of gastrointestinal adsorption through oral application was possible, allowing access at least to the synapses of the submucous and /or myenteric cholinergic nerve plexuses in the intestinal wall thereby producing inhibition of intestinal peristalsis. At this point I have to mention, that the increase of lipophilicity and thereby better access to peripheral neuronal receptors by introduction of longer alkyl and aralkyl, instead of methyl quaternary groups has been demonstrated by me as early as in 1953, when for the first time the presence of a slowly developing and long lasting local anesthetic action of certain quaternary derivatives of both “exo and endo” benzoyl tropines has been demonstrated (22). It would be tempting to propose that in the intestinal spasmolytic action of the Buscopan and Gastripon-type agents a local anesthetic, cation channel blocking action may be also instrumental. Since the spasmolytic action after the oral intake of few milligrams of Buscopan or Gastripon becomes apparent it seems unlikely that their allegedly weaker, ion channel blocking action may become clinically contributory. At this point it seems to be appropriate to refer to the interesting early concept of Zipf, who already in the fifties proposed the theory of “endo-anesthesia (23); that refers to a generalized, sensory nerve blocking “anesthetic” action affecting primarily the non myelinated or sparsely myelinated C and delta A type sensory nerves. Such action is attainable by large, i.v. bolus doses or infusions of potent local anesthetic agents. This generalized endo anesthetic, e.g. “numbing” effect on systemic, intravenous application remained less than fully exploitable mainly because of the systemic toxicity of the common “local anesthetic” agents. However examples of regional intravenous limb anesthetic techniques have already proved that Zipf’s principle, within limits, is tenable, and with possible molecular design and/or pharmacokinetic manipulations it could lead to a revolutionary new version of “general anesthesia”. It was unfortunate that the large number of quaternary derivatives of many tropane derivatives have not attracted enough interest for detailed molecular pharmacological studies on ion channels and that their pharmacokinetic analysis also escaped attention up to date in spite of their potential therapeutic interest as novel “endoanesthetic” agents. Only few quaternary ammonium type agents have been studied more intensively as cation channel blocking agents. Among these, the trimethyl quaternary analog of lidocaine (QX 215/Astra) and its ethylquaternary derivative (QX 222/ Astra), underwent detailed neurobiological testing some thirty years ago and reviewed later (24). Why did only these



two, highly hydrophilic quaternary agents capture the interest of neurophysiologists? The question remains unanswered up to date.

*My connections to Cocaine.* The extent of my work with cocaine, (an ester of ecgonine) as compared with that of tropine esters, has been limited. There were several reasons for this. Foremost, I was interested in the exploration of the anticholinergic spectrum of action of quaternary ammonium –type tropane derivatives. For such studies Cocaine was practically unsuitable. First, cocaine itself did not show significant pharmacologic actions on acetylcholine receptors. Furthermore its chemical structure, with a carbomethoxy radical in exo- position, in the vicinity of the tropane N- atom, hindered the introduction of even smaller sized quaternizing groups. Later in the US I developed interest in Cocaine and its derivatives in relation to Serotonin and Nicotinic Pharmacology, and developed a plan to use the large amount of confiscated Cocaine in the US as starting material for the synthesis of different classes of new therapeutics. That category of my professional activities has been recently referred to in the “Archives of International Network for the History of Neuropsychopharmacology”; and listed few new “Cocaine derived” epibatidine analogs with nicotinic stimulant, spinal analgesic and neuromuscular blocking properties (Gyermek Collection, February 13, 2017).

### **Tropane- type neuromuscular blocking agents. An exploratory trip from succinylcholine, through succinyltropine to new, ultrashort acting myorelaxants.**

During the study of the first, early myorelaxants with the tropane ring system I was primarily involved in the pharmacological analysis of the role of the terminal quaternary ammonium groups. In the tropane ring, the quaternary N atom, being in a central, wedged-in position has only one free valence. Therefore in the case of the early bis-quaternary tropane derivatives, where the two tropane rings have been connected through the N atoms by different linker components, these become integral part of the quaternary ammonium group and would not allow the introduction of another functional group on the N atom, unless the N-methyl radical, originally present in the tropane ring, would be removed. The elimination of this methyl group represented two problems: First, the early structure-activity rule of myorelaxants indicated that for the neuromuscular blocking property the presence of at least one methyl substituent in the “cationic head” should be present. Second, the replacement of the N- Methyl group in tropane can be done only via nor-tropine, the synthesis of which is more complex and costly. Therefore with Nador we have decided to transpose the “linker” component from the N atom of tropine to its 3-OH

group, forming diester linkages. By this approach of connecting two tertiary tropane rings the introduction of various quaternizing groups at the terminal N atoms became possible. As another element of the molecular design we also had to take into account the importance of the functionally important “inter –onium” distances, assuring 14-15 Angstrom length between the two N atoms of the molecule, which corresponded roughly to an 10 C-C bond distance.

This distance was best achieved, at least with linear modeling, by the succinic acid ester of tropine. This tropine derivative could be considered as a bicyclic ring analog of succinylcholine (Figure 22) that has been the best known depolarizing-type myorelaxant. Initially we synthesized and investigated five quaternary bis succinyl and phtaloyl tropinesters in 1952 (25). It was almost co-incidental that at the

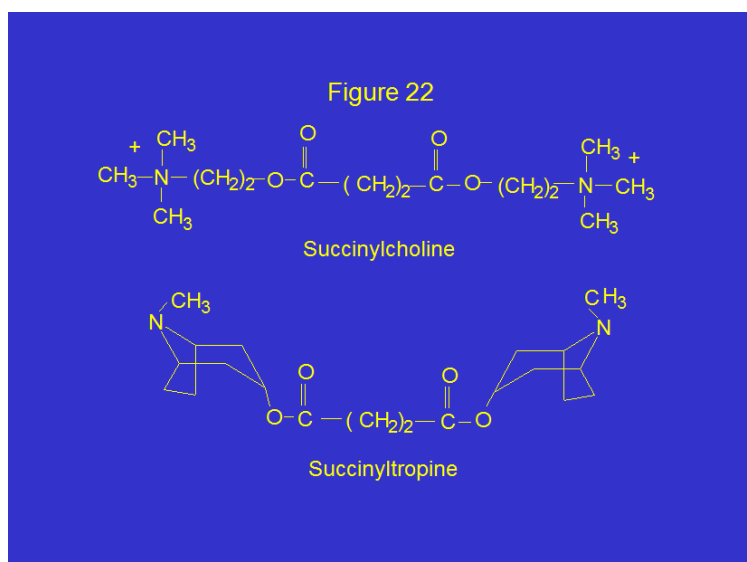

same time Boehringer Ingelheim, the German pharmaceutical company, that has been active in the field of tropane alkaloids developed the ethyl quaternary derivative of Belladonnin one of the naturally occurring few dimer tropane alkaloids (26). This compound underwent clinical evaluation, but because of its strong cardiac accelerating effect, it has been abandoned. Such side effect has not been surprising since the dicarboxylic acid component of Belladonnin is structurally similar to tropic acid, present in the strongly antimuscarinic agent atropine. It was interesting to observe that the duration of neuromuscular blocking effect of these first bis quaternary dicarboxylic acid tropine esters has been considerable shorter than that of d-Tubocurarine, at that time the reference standard for NMB agents.

After having settled in the USA I could not continue my work with the tropane type myorelaxants. The first such opportunity came about in 1962 while I have been associated with Syntex Laboratories in Palo

Alto, California, where I have met a former chemist friend from Hungary, Imre Bacso, who has had experience with tropane chemistry, and who was willing to synthesize a few new dicarboxylic acid tropine esters; of course “unofficially” and in overtime, because at that time Syntex was highly specialized in Steroid research. Still at that time, as head of the Pharmacology Division, I had enough freedom to carry on a limited scale investigation with few additional tropane-type myorelaxants. At that point it was interesting to observe that the longer sebacic acid ester linker yielded more potent agents than found with the succinyl-, glutaryl -and phthaloyl linkers- containing tropine diesters. This observation has called our attention first to the “conformational plasticity” of the longer chain-containing, flexible, aliphatic acid esters of tropine and to the possibility, that these in the moment of their “attachment” to the “bipolar” neuromuscular nicotinic ACh receptors, may change their, thermodynamically predetermined “free form” conformation, and, by a degree of flexion, may still effectively attach to the binding sites of the ACh receptors located close to the outer margin of the ion-channel-receptor complex.

To my regret I could not return to the research of the tropine diester myorelaxants for more than two decades because of my full time engagement with clinical anesthesia. Only when I have joined Harbor-UCLA in 1986 could I finally start a limited scale laboratory research in part time; and first single handedly have synthesized a few dozen new dicarboxylic acid tropine esters and also have produced several hundreds of their quaternary ammonium derivatives. Concurrently we have started to pharmacologically evaluate these new agents, first on rats with the cooperation of Chingmuh Lee, at that time the chairperson of the Anesthesiology Department, who being himself a researcher in the field of muscle relaxants, has showed interest in the project. Based on the first promising results, the two of us worked out a research project program for new, ultra-short acting, non-depolarizing muscle relaxants, which were not available for clinical practice. First with the support of Borroughs-Wellcome and later of Organon Laboratories employing a full time research Chemist: Dr. Young Moon Cho and with our departmental research Associate: N. Nguyen our small research group could increase the scope and intensity of research into such agents. The only clinically used rapidly and short acting muscle relaxant has been succinylcholine, already in clinical use since the 1950s. Its main clinical disadvantage derived from its mechanism of action; it produced muscle relaxation by depolarization of the muscle end plates. Therefore the new, ideal short acting muscle relaxant agents had to be of the non depolarizing type. Increasing the size of the cationic head in succinylcholine by Bovet and his associates, developers of

succinylcholine, (27) resulted in non depolarizing type of myorelaxant action, but with diminished overall potency (28). Our findings with the first bis- quaternary tropanyl diesters, already in the fifties, showed relatively short myorelaxant action. With this information we felt confident that by a detailed study of the three most important structural elements present practically in all myorelaxants: namely the quaternizing terminal groups and the type and length of the connecting chain we can further improve on the potency, speed of onset, duration of action and side effects- profile of our new tropanyl diester type myorelaxants to the extent that a clinically useful new agent could be launched. Therefore we undertook the detailed study of the following aspects: 1) The role of the quaternizing groups studying methyl and higher alkyl, and aralkyl groups, such as benzyl- and naphthylmethyl, and many of their substituted analogs. Much emphasis has been placed on such substituents on the benzyl group as: halogen-, alkyl-, alkoxy- and acyloxy-; 2) the role of the structurally different dicarboxylic acid ester linkers (e.g. aliphatic and aromatic dicarboxylic acids), their length and site of attachment to the tropane ring (e.g. either to the C3 or C2 atom) (Figures 23, 24); 3) the role of reversing the diester function by comparing diesters of tropane- 2-and 3- carboxylic acids; 4) the role of linkers attached to the N atom of the tropane ring. Furthermore, at least to some extent we also studied the role of the stereochemistry on the quaternary N atom of the tropane ring in the case of N-N linkers (which can influence the entire shape of a tropane bisquaternary molecule) and the role of the stereochemistry of the terminal substituents on the cationic head (29,30).

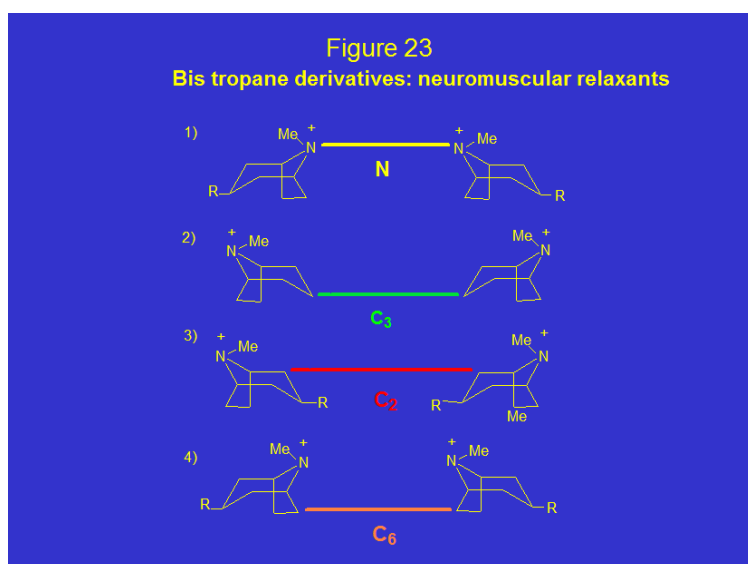

Figure 24

**N linker** = alkyl, aralkyl (e.g.p xylyl) chains,  
alkyl - or aralkyl esters

**C<sub>1</sub> linker** = alkyl,- alkenyl,- alkynyl diesters  
or aralkyl diesters, also reversed  
diesters (e.g tropane 3 carboxylic  
acid alkyl diesters)

**C<sub>2</sub> linker** = alkyl, alkenyl diesters of tropane-2ol  
also reversed diesters (e.g.tropane-  
2-carboxylic acid alkyl esters)

**C<sub>6</sub> linker** - hypothetical diesters of 6-OH tropane;  
(also of naturally occurring 2,6 ; 3,6 -  
dihydroxy and 3,6,7 trihydroxytropans)

In a short review I can illustrate only a few examples of the detailed chemical pharmacology work, which encompassed well over one thousand tropane derivatives; and on and off took some fifty years. Of these the most relevant were the evolution of the type and optimal length of the “interonium” connecting chains, and the quaternizing radicals (Figures 25 and 26). Concurrently we devoted significant work on the role of different, eg. halogen-, alkyl-, alkoxy -and acyloxy substituents on the benzyl groups (Figure 27). [Note: In Figures 25-28 RI represents : recovery index, the recovery time elapsed from 75% to 25% NBM ) CVB represents per cent cardiac vagal block at 80% NMB level].

Figure 25

NMB profile of Methylquaternary derivatives of tropinyl diesters in the rat  
(Ref. 29)

Dicarboxylic Acid linker	NMB ED50 μ mole/kg	Onset min	RI min	CVB % *
C2	>2.5	1.3	5.0	0
FU	5.0 (0.38)	1.0 (0.07)	2.5 (0.01)	0
C3	4.7	1.2	4	0
C4	> 4.7	1.5	4	100
C5	2.3 (0.1)	1.4	6.5	0
C6	1.3 (0.08)	1.4	3.5	100
C7	0.6 (0.05)	1.4	2.5	-
C8	0.8 (0.04)	1.3	2.0	100
C9	~ 0.6	1.0	2.0	-
C10	1.2 (0.06)	0.9	2.0	100
C11	1.0 (0.06)	1.0	3.0	--

Figure 26

Optimization of the quaternary groups for improved neuromuscular blocking properties in the glutaryl bis (endo) tropinium series \* (Ref. 29)

Quaternary group	Neuromuscular block ED50 micro mole /kg	Onset of action min.	Recovery index min.	CVB + %	N
Benzyl	4.8	1.8	3.7	53	6
4-MeO Benzyl	2.0	1.1	1.6	85	3
2,6 di Cl Benzyl	1.3	1.2	3.5	80	6
2,5 di MeO Benzyl	0.3	1.2	2.2	65	5
4-Acetoxy-3,5-diMeO Be	1.1	0.5	0.7	50	6
3,4-Diacetoxy Benzyl	0.29	0.8	0.6	10	7
3,4-Dipropionyloxy Benz.	0.36	0.7	0.5	0	3

\*On anesthetized rats.

+ CVB = cardiac vagal block in per cent at 80% neuromuscular block

Figure 27

NMB profile of 3,4-diacetoxybenzyl quaternaries in the rat (Ref. 29)

Acid ester Linker	NMB ED50 $\mu$ mole/kg	Onset min	R.I min	CVB %	N
C2	0.17(0.01)	0.7 (0.1)	0.5 (0.05)	26 (15)	5
C3	0.29 (0.04)	0.75(0.1)	0.55(0.04)	7 (2)	9
C4	0.55(0.02)	0.75(0.1)	0.6 (0.1)	35(12)	4
C5	0.23(0.03)	0.75(0.1)	0.55 (0.1)	77 (4)	5
C8	0.17 (0.02)	0.5 (0.1)	0.5 (0.05)	90 (6)	5
C9	0.3 (0.02)	0.8(0.1)	0.5(0.05)	98 (2)	5
C12	0.48 (0.03)	1.1(0.05)	1.2 (0.05)	100	3
FU	0.40(0.07)	0.9(0.1)	0.9 (0.1)	1 (0.1)	8
CB	0.27 (0.02)	0.7(0.1)	0.45 (0.05)	5 (3)	10
PHT	0.64(0.15)	0.8(0.1)	0.6(0.02)	24(11)	4
IPHT	0.3 (0.05)	0.7(0.05)	0.5 (0.02)	12(6)	5
TPHT	0.28(0.02)	0.65(0.1)	0.45(0.05)	23(11)	4

Since the pharmacologic potency, pharmaco-kinetic profile and side effect- characteristics are highly species dependent many compounds had to be tested beyond the screening on anesthetized rats on additional animal species. Particularly the different acyloxy benzyl quaternary derivatives of a few selected dicarboxylic acid tropine esters undergone more detailed animal laboratory evaluations, including juvenile pigs and sometimes also rabbits, ferrets, cats, dogs and monkeys (Figure 28).

Figure 28

Comparison of the NMB profile of TAAC3 in different animal species  
(Ref. 32)

Species	NMB ED50 $\mu$ mol/kg	Onset min.	RI min.	CVB %	N
Rabbit	0.08 (0.02)	0.9 (0.1)	0.7 (0.05)	-	6
Guinea pig	0.05 (0.01)	1.0 (0.06)	0.8 (0.15)	5 (3)	5
Cat	0.25 (0.05)	1.0 (0.02)	0.6 (0.05)	8 (2)	3
Dog	0.14 (0.04)	0.9 (0.05)	0.6 (0.05)	-	6
Pig	0.20 (0.04)	0.95(0.1)	1.1 (0.1)	41(3)	6
Monkey	0.1 (0.01)	0.9 (0.1)	0.7 (0.1)	-	6

From such more elaborate evaluations two agents emerged: in 1990, G-1-64, the 2,6-dichloro benzyl quaternary of glutaryl tropine, synthesized by me (31) and in 1998, TAAC3 (later labeled as Org 25415), the 3,4- diacetoxy benzyl quaternary of glutaryl tropine synthesized by Dr. Y.M.Cho (32). We applied for and obtained four US Patents for the design, preparation and use of different new bis quaternary tropinyl (and granatanol) diester molecules. For a small research group that has been, I believe, a substantial achievement. Further, Organon NV the Dutch Pharmaceutical Company to whom we have licensed our inventions has helped us, up to 2002, with the synthesis and evaluation of additional new tropane type myorelaxants, particularly derivatives of TAAC3 / ORG 25415. This agent came close to clinical studies. Unfortunately toxicological experiments at Organon with its repeated – large dose administration to cats and dogs produced kidney toxicity, manifested in acute tubular degeneration due to a rapidly forming toxic quinone methene metabolite from the crucially important 3,4,diacetoxybenzyl quaternizing group (Figure 29) (33).

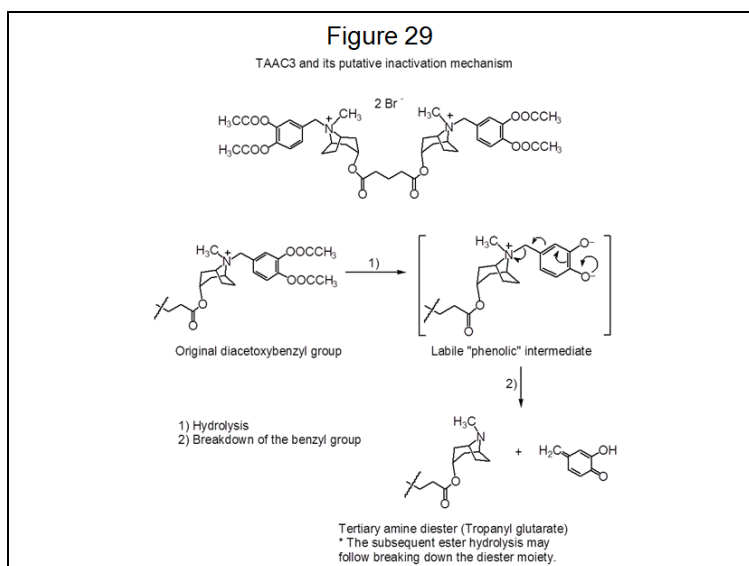

An interesting and challenging aspect of the chemical pharmacology, related to the tropane skeleton, is the stereochemistry of the substituents of the quaternary, tetravalent N atom. This aspect has not been extensively studied (Here I would merely like to refer to some other studies with practical significance). Early stereochemical studies have shown that the orientation of the N-Me group in tropane and tropine is perpendicular, e.g. axial (a) to the longitudinal axis of the bicyclic ring. By quaternization of the N the new substituent is directed parallel with the longitudinal axis of the ring system occupying an equatorial (e) position (cf 13). Accordingly, with single tropane quaternary compounds two N enantiomers occur, usually with a strong preponderance of the Me (a)-N- AR (e) species (Figure 30). For example with the p-phenylbenzyl quaternary of atropine (such as Gastripon, our previously marketed gastrointestinal spasmolytic) the orientation of the group (AR) is over 80% equatorial (34 a). The anticholinergic spectrum of action of the Me(a)-N- PhBe (e) is significantly different from that of the Me (e)-N- PhBe (a) species. In the case of the broncholytic anticholinergic tropinesters Ipratropium (Engelhardt, 34 b) (Atrovent, Boehringer- Ingelheim AG) and Flutropium (Badische Anilinwerke 598 BR) which contain the isopropyl and fluoroethyl quaternary substituents, respectively, in the axial and the N-Me groups in equatorial position, such "reversed" N enantiomers (Figure 31) proved to be favorable therapeutically on the account of their affinity profiles to different muscarinic ACh receptor subtypes.



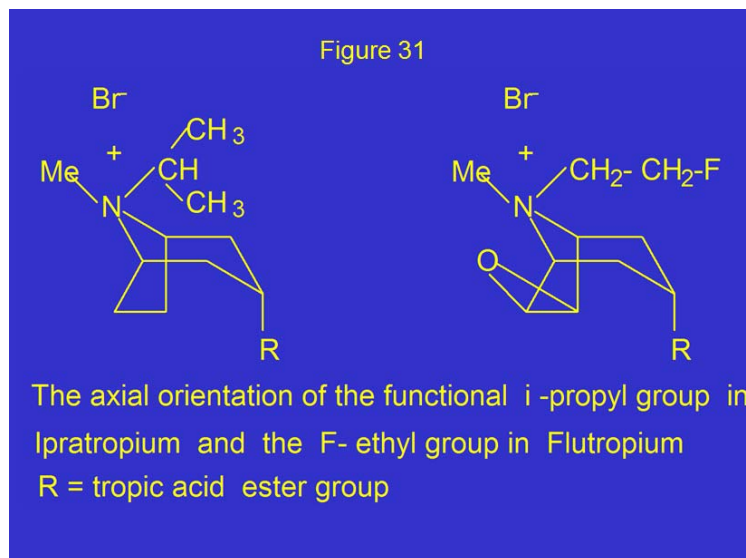
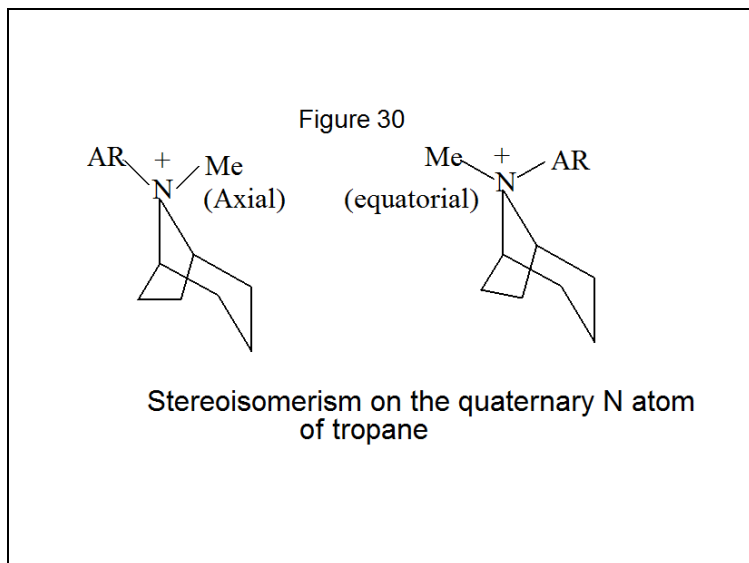

While with monoquaternaries of tropane there are two species of N enantiomers; in the case tropane dimers, exemplified by different types of bisquaternary tropane derivatives, there are three epimers possible, namely the Me-N- AR----- AR-N-Me oriented pair (type I), the Me-N-AR..... Me- N-AR oriented pair (type II), and the AR-N-Me ----- Me-N-AR oriented pair (type III) (Figure 32). With TAAC3 we have studied the NMB profile of only two pairs of N epimers pharmacologically. These, in respect to the N-Me groups were the “anti-anti” (Type I) and the “anti-cis” (Type II) variants. In rats, the NMB spectrum of action of the two epimers, were quite similar. (It would have been important to investigate the third epimer with the “syn-syn” configuration, but this species was difficult to isolate / synthesize). Our results on rats were similar to those of Haining and Johnston (35), who already in 1960

have reported similar NMB potencies on cats with two pairs of N-enantiomer bis tropine esters which were connected on the N atoms of tropine through aliphatic ester groups and contained the Me-N-CH<sub>2</sub>CH<sub>2</sub>-O- and the -O-CH<sub>2</sub>CH<sub>2</sub>-N-Me cationic head (Figure 33).

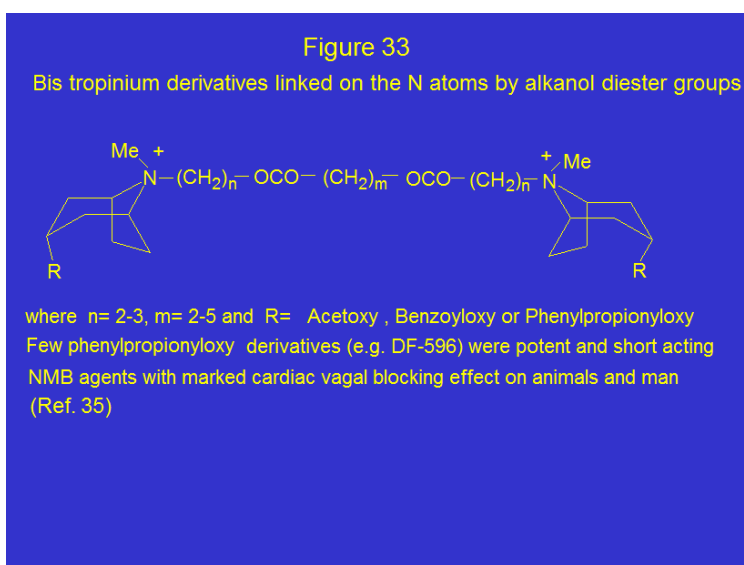
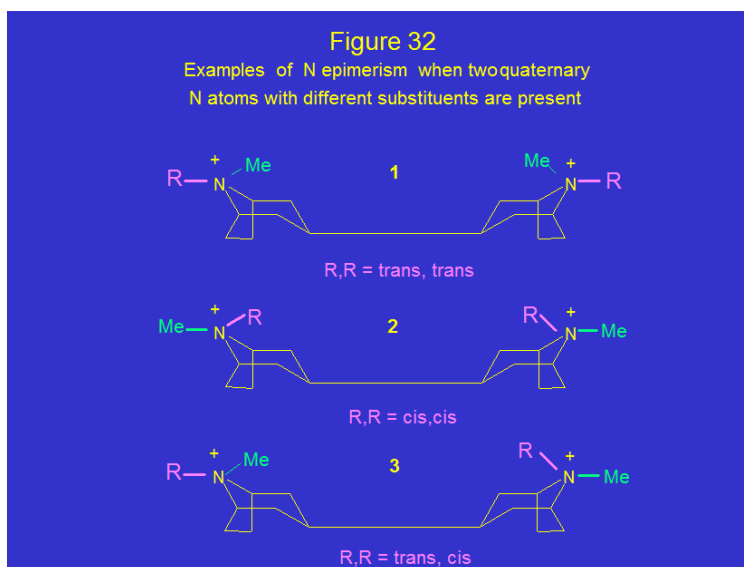

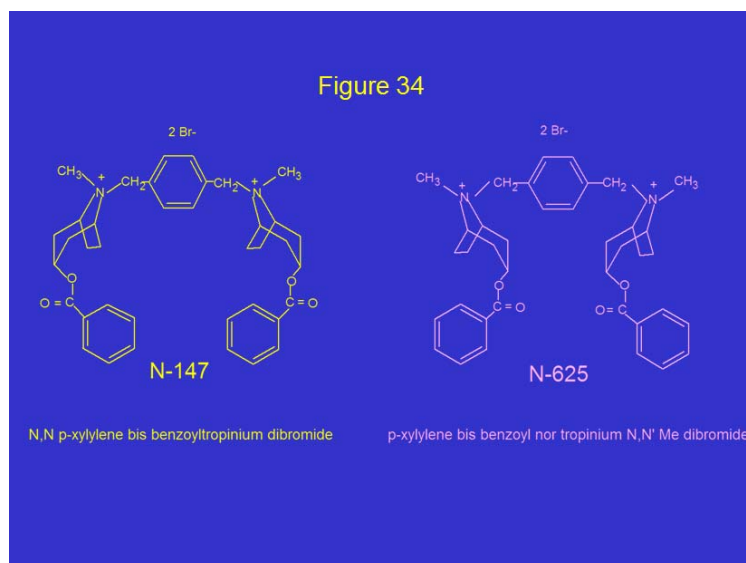

Altogether this, although sketchy information indicates that in the case of the neuromuscular blocking bisquaternary tropinyl diesters the flexibility of the linker component permits the optimal orientation of the terminal onium cationic groups to the binding sites of the neuromuscular n ACh receptors. In case of rigid linkers between the terminal N atoms, exemplified by the previously mentioned N- p Xylylene-N bisquaternary derivatives N-147 vs. N-625 (Figure 34) the binding conditions to the receptors are favorable only with one N-epimer (N-147) because the rigid linkers cause a significant alteration of the overall shape of the molecule.

Further studies into bisquaternary N- epimers may offer significant help in exploring the binding characteristics and geometry of the “binding pockets” of the neuromuscular n ACh receptors; one of which is located on the border of the alpha/ delta subunits and the other at the margin of the alpha / epsilon subunit. These binding pockets may possess different degrees of binding affinity to the two terminal onium groups of bisquaternary type NMB agents.

The majority of drugs that contain the tropane ring system are either naturally occurring or synthetic ester derivatives of tropine where the ester group(s) are attached to the 3 endo positioned OH group of tropine. Considerably fewer, pharmacologically explored and sometimes valuable tropan -ol esters are known where the ester group(s) are formed with 2 and/or 6 positioned OH groups. 2-OH tropane derivatives were first studied by Wichura in 1919 (36). We investigated a few bis quaternary tropane

(endo and exo) 2-ol diesters as NMB agents (29) which were generally less potent than the corresponding tropine ( e.g. tropan- 3 ol) diesters.

Few tropine ether derivatives are known. Here the therapeutically explored and utilized agents are just a handful. Of these benztropine and the corresponding N –ethyl derivative: N- ethyl benz nortropine (37,38) were shown to have therapeutic potential as antiparkinsonian agents.

A series of pseudotropine phenylethers, substituted on the benzene ring were shown to possess nor adrenaline potentiating and anti-cataleptic properties in animals (38).

*Modifications within the tropane skeleton.* Transposition of the N atom in tropane from 8 to 6 position. We have synthesized several bisquaternary derivatives of 6 -azabicyclo (3.2.1) octane 3 (endo)-ol diesters and investigated them for NMB properties. Some of them had similar spectrum of action to the corresponding 8 azabicyclo analogs, but none of them showed superior NMB characteristics (29). Further, we explored the role on neuromuscular potency of introducing a double bond between the 6 and 7 C atoms into the tropine ring without finding superior NMB agents over the corresponding, original tropinyl diesters (29 30).

*The role of introducing the (exo) 6-7 epoxy bridge into tropine derivatives.* The only significant tropinesters with such epoxy groups are: l-hyoscine (scopolamine) with characteristic central nervous system effects and its N-butyl quaternary derivative (Buscopan) an anticholinergic, spasmolytic and antisecretory agent mentioned earlier (21). The NMB characteristics of few quaternary derivatives of scopolamine proved to be unsuitable for further development. While the common belief is that the unique psychopharmacologic effects of scopolamine are attributable to the exo oriented 6-7 epoxy group of l-hyoscine; it seems possible that the optical isomerism of the tropic acid component also plays a role. I am not aware of any psychopharmacological study which have dealt with the exploration of either the racemic *dl*- troyl scopine, or the *d-troyl* ester. Along these lines to study the tropic acid esters of *beta* scopine would certainly be of interest.

*Diazabicyclo octanes.* Several series of 3,8 diazabicyclo (3.2.1) octanes were studied and some of them are illustrated (Figures 35, 36 and 37). Primarily type III antiarrhythmic and analgesic properties were assigned to these agents (39, 40, 41)

*Changing the configuration and/or size of the tropane skeleton.* Further changes within the subclasses of azabicyclo octanes, reflected in pharmacological studies included primarily quinuclidine (1-azabicyclo 2,2,2 octane) derivatives (Figure 38). Among these mostly the 3-hydroxy substituted aromatic acid esters were studied for antimuscarinic type of actions. (cf. 29, 30). We investigated only a few bis quinuclidinium compounds for NMB action-profile; and found only weak NMB potency. Since with the quinuclidine derivatives the branching of the alicyclic skeleton at the alpha position relative to the N atom is missing, the unfavorable results on nicotinic NMB (and ganglionic) ACh receptors further emphasized the importance of this branching moiety present in the tropane ring.

Figure 35  
GENERAL STRUCTURE OF ANALGESIC  
3,8- DI AZABICYCLO OCTANES I.  
(Ref. 39,40)



where R = H, CO C<sub>2</sub>H<sub>5</sub> or CH<sub>2</sub>CH=CH Aryl and R' = H,  
CO C<sub>2</sub>H<sub>5</sub> or CH<sub>2</sub>CH=CH Aryl  
(where the aryl group can be substituted with  
halo, methyl or nitro groups).

Figure 36  
 GENERAL STRUCTURE OF ANALGESIC  
 3,8-DIAZABICYCLO OCTANES II.  
 (Ref. 39,40)



where R and R' = H, or a chlorinated heteroaryl ring .  
 Most potent was the R=H and R' = 6 chloro 3-pyridazinyl  
 derivative, which produced "epibatidine-like" nicotinic  
 type analgesia in mice.

Figure 37  
 GENERAL FOMULA OF  
 CLASS III. ANTIARRHYTHMIC 3,8-DIAZABICYCLO OCTANES  
 (Ref. 41)

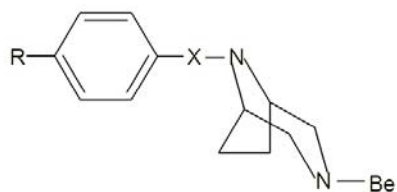

where R= NO<sub>2</sub> or NH-SO<sub>2</sub>CH<sub>3</sub> X= CO or OCH<sub>2</sub>CH<sub>2</sub>  
 and Be= benzyl

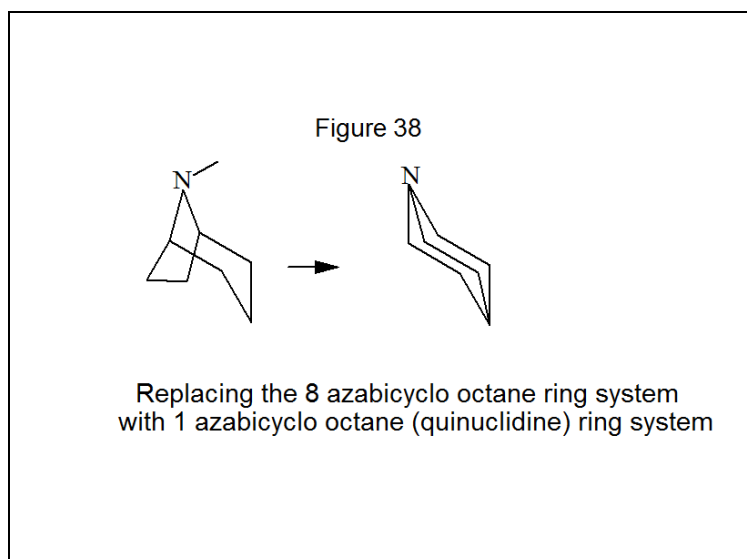

The role of reducing the tropane ring to 7 azabicyclo (2.2.1) heptanes (Figure 39) has come into focus of interest in neuropharmacology since the discovery of epibatidine (42),(Figure 18), an impressively potent nicotinic stimulant present in the skin of a small tropical frog: *Epipedobates tricolor*. This agent has been shown to have extremely high affinity to different nicotinic receptor subtypes, and accordingly has shown strong nicotinic analgesic as well as toxic effects. In the unique efficacy of this alkaloid the presence of an *exo*- orientated pyridine ring on the C2 atom of the azabicyclo- skeleton and its steric orientation to the secondary amino group in the 7 position has been essential. We have studied a few bis quaternary 7 azabicyclo (2.2.1) heptan 2-ol diesters for NMB profile, which were generally much inferior in potency and side effects- profile as compared to the “corresponding” azabicyclo octane (Tropane) derivatives (29).

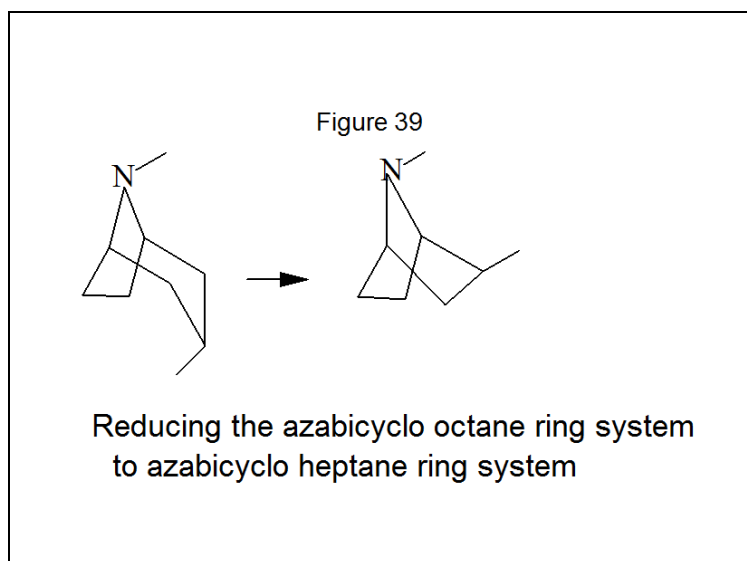

Increasing the size of the azabicyclo octane by one C atom leads most conveniently to the best known, symmetric azabicyclo nonane ring system: 9-Azabicyclo (3.3.1) nonane (Figure 40), which is found in the form of its N-methyl, 3-OH derivative, the pomegranate alkaloid Granatanol.

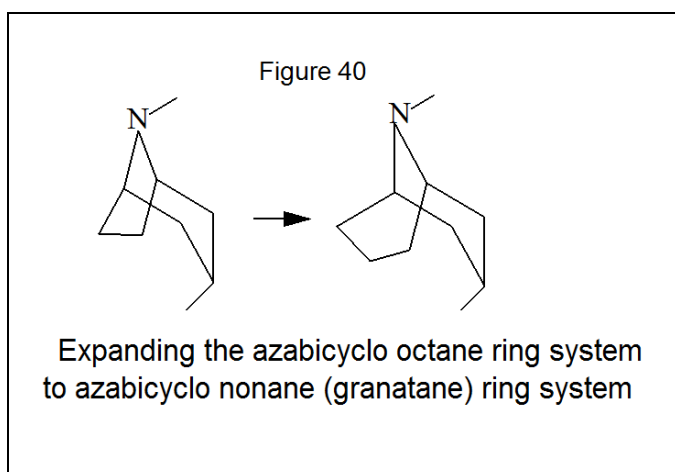

In spite of the easy synthesis of the granatanol ring, much fewer azabicyclo (3.3.1) nonane than tropane derivatives were explored pharmacologically. We have synthesized and pharmacologically investigated over fifty bisquaternary granatanol diesters as part of a logical extension of our detailed study of similar tropanes for NMB (43). Figure 41 illustrates the NMB characteristics of few highly potent bisquaternary “granataninium” diesters; and demonstrates that some of them not only slightly surpassed the corresponding tropane esters in potency, but with respect to onset and duration of NMB action, few of



them proved to be the fastest and shortest acting nondepolarizing NMB agents in experimental animals, hitherto described.

It is noteworthy that the granatane ring system also provided a building block for a highly potent, clinically used 5-HT<sub>3</sub> receptor antagonist antiemetic agent, Granisetron. (44) Thus further interest in azabicyclononanes or even perhaps larger azabicyclo ring systems in new drug design seems to be justified.

**Figure 41**  
NMB profile of a series of 3,4-diacetoxybenzyl quaternary derivatives of 9-azabicyclo (3.3.1) octane 3  $\alpha$ -ol (granatanol) diesters. (Ref. 43)

Acid ester	NMB ED50 $\mu$ M/kg	Onset	RI	CVB	N
C2	0.19 (0.07)	0.6 (0.05)	0.55 (0.05)	70 (10)	6
C3	0.2 (0.04)	0.6 (0.04)	0.45 (0.05)	0	8
C4	0.17 (0.06)	0.5 (0.04)	0.4 (0.05)	14 (3)	10
C5	0.2 (0.02)	0.45 (0.05)	0.4 (0.05)	0	8
C6	0.52 (0.12)	0.4 (0.1)	0.35 (0.05)	75 (15)	4
FU	0.38 (0.06)	0.55 (0.03)	0.45 (0.04)	0	8
CB	0.15 (0.03)	0.5 (0.05)	0.45 (0.04)	2 (2)	4

At this point I would like to mention that after I have left Hungary in 1956, the work we carried out on tropane derivatives in the Research Institute of the Pharmaceutical Industry has been continued in the Experimental Medical Research Institute of the Hungarian Academy of Sciences; where a research group under the direction of K. Nador, L. Gyorgy and M. Doda has made significant contributions. First they discovered that certain quaternary derivatives of N-ethyl nor- tropine esters surpassed the potency and selectivity of similar quaternary tropine esters (with the inherent N-Me group (37); and, as mentioned earlier they described centrally potent topine ethers (38). Furthermore they demonstrated that some tropine and granatan-ol esters possess not only ganglionic blocking, but also postjunctional adrenergic nerve-blocking property (45,46). They further explored the anticholinergic spectrum of action of few quaternary N- enantiomeric pairs of tropane compounds, including that of Gastropin (47, 48). Subsequently Boehringer Ingelheim in Germany started to pay interest to some N- enantiomeric pairs of the tropane class. This work has led to the clinical

introduction of Ipratropium (Atrovent (34 b), which is the N- enantiomer of N-isopropyl atropinium bromid , with the reversed steric positions of the N-Me and N\_isopropyl groups (Figure 31). Thus the therapeutic success of Atrovent and similar new tropane – based bronchodilator agents has had obvious chemical design-roots in the early studies in Hungary with the N–enantiomers of tropine and atropine.

In a single, relatively short review presentation it was clearly impossible to describe or even just list all pharmacologically important tropane derivatives, particularly with a potential perspective into similar azabicyclic ring systems. In summary one can say that the tropane ring with its three dimensional structure, including a bicyclic ring of eight atoms, representing a fusion of a piperidine and pyrrolidine ring, and with a shared, centrally wedged in N atom, is a structure with high pharmacologic significance. Because of its shape and two alpha branching C atoms next to the N atom (Figure 43), it can be considered not only as an “umbrella” as proposed by Pfeiffer first (49), surrounding the small, trimethylammonium-type “cationic” head of ACh, but also as a shield or even cage for “covering” several “monoamine” – linked biological receptors. The tropane ring with a protonated, substituted

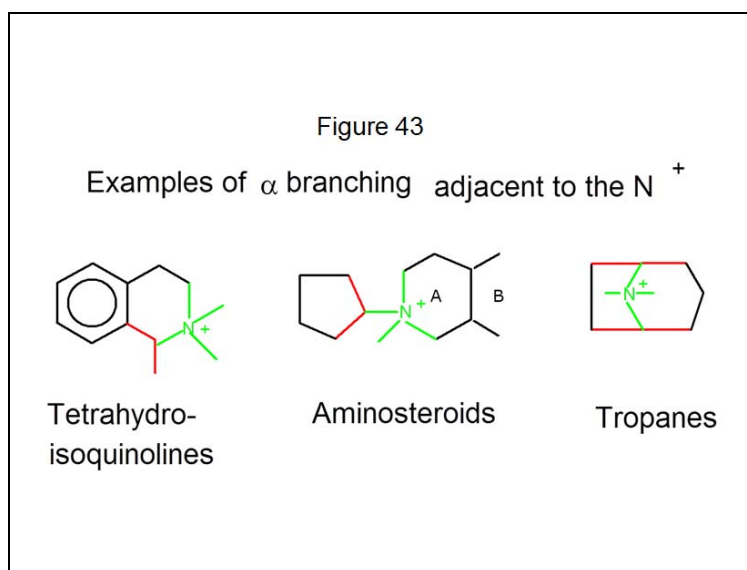

N atom alone can cover the small, trimethyl ammonium cationic head of acetylcholine at nicotinic ACh receptors. This shielding effect can be contributory, but not essential to prevent the docking of ACh to various, mostly M2 and M3 type muscarinic receptor sites. In case of nicotinic ACh receptors, preventing the” ACh cationic head- receptor- anionic site interactions” is more significant. The high binding affinity/ blocking potency of mono quaternary tropane compounds to peripheral neuronal

nicotinic ACh receptors and of bisquaternary tropane compounds to peripheral muscular nicotinic receptors became obvious in the last few decades. Besides the “caged” N atom, in the case of muscular nicotinic ACh receptors, the “twinning” of the tropane moiety and fulfilling the affinity- requirements to some electronegative receptor groups, exemplified by the structures of highly potent tropinyl “diesters” and reversed” diesters” proved to be important. Thus the rank order of the importance of the tropane skeleton, in relation to peripheral cholinergic receptor sites is: ganglionic nicotinic > neuromuscular nicotinic > muscarinic. The role of the tropane ring in relation to “shielding” the receptive sites of other monoamine receptors remained less explored. Yet many compounds with tropane components have already emerged showing high affinity/ potency at certain dopamine-, serotonin- and catecholamine linked receptors and / or transporter proteins. The pharmacological importance and possible practical significance of the tropane ring system will certainly expand as a useful and versatile scaffold in molecular drug design for both ACh and monoamines- targeted therapeutic researches, and perhaps even beyond those.

In closing, I would like express my appreciation to your kind attention and my thanks to the membership of the Hungarian Academy of Sciences for awarding me with the Academic Membership status. Finally my thanks are also extended to the Administrative Offices of the Academy for the scheduling, audio-visual and reception - related aspects of this lecture.

## References

1. Lounasmaa M, and Tamminen T (1993) The Tropane Alkaloids. In: The Alkaloids. Vol 44, Chemistry and Pharmacology. ( Cordell GA, ed.) pp 1 -115. New York: Academic Press.
2. Dale H. The action of certain esters and ethers of choline and their relation to muscarine. J Pharmacol exp Ther 1914; 6: 147- 190.
3. Robinson R. Synthesis of tropinone. J Chem Soc 1917 ;111: 762-768.
4. Issekutz B. Über die wirkung der tropeine und ihrer quaternere ammoniumbasen. Z exp Pathol Ther 1917; 19: 99-117.
5. Hildebrandt H: Zur pharmakologie der Ammoniumbasen. Arch Exp Pathol Pharmacol 1905; 53: 73-96.
6. Kimura KK, Unna KR, Pfeiffer CC. Diatropine derivatives as proof that d-tubocurarine is a blocking moiety containing twin atropine-acetylcholine prosthetic groups. J Pharmacol exp Ther 1949; 95: 149-154.
7. Kimura KK, Unna KR. Curare –like action of decamethylene-bis- (atropiniumiodide). J Pharmacol exp Ther 1949; 98: 286-292.
- 8 Barlow RB, Ing HR. Curare like action of polymethylene bis-quaternary ammonium salts. Nature 1948; 161: 718-719.
9. Paton WDM, Zaimis E. The pharmacological actions of polymethylene bistrimethyl ammonium salts. Brit J Pharmacol 1949; 4: 381-400.
10. Gyermek L, Sztanyik L The ganglionic blocking activity of tropeines. Acta Physiol Hung 1951; 2: 41-47.

11. Gyermek L. The ganglion blocking action of the tropine and tropinium. *Acta Physiol Hung* 1951; 2:175-177.
12. Gyermek L, Nador K. Studies on cholinergic blocking substances II. Correlations of the antimuscarine, antinicotine and curare-like effects of mono and bisquaternary tropeines. *Acta Physiol Hung* 1952; 3: 283-293.
13. Gyermek L and Nador K: The pharmacology of tropane compounds in relation to their steric structure. *J Pharm Pharmacol* 1957; 9: 209-229.
14. Gyermek L: ( 1967) Ganglionic stimulant and depressant agents. In: *Chemical Constitution and Pharmacodynamic Action*. Vol I. (A Burger, ed,) pp 149-326. New York: Marcel Dekker Publ.
15. Gyermek L and Nador K. Pharmacology of (p-biphenylmethyl-dl-tropyl-tropinium bromide). *Arch Int Pharmacodyn* 1957; 113:1-14.
16. Gyermek L, Nador K : *Pharmakologie von neuen, die vegetative ganglien reizenden verbindungen*. *Die Pharmazie* 1955; 10: 238-244.
17. Conti-Tronconi BM, Raftery AA. The nicotinic cholinergic receptors, correlation of molecular structure with functional properties . *Ann Rev Biochem*. 1982; 51: 491-530.
18. Holladay MW, Dart MJ, Lynch JK . Neuronal nicotinic acetylcholine receptors as targets for drug discovery. *J Med Chem* 1997; 40: 4169- 4194.
19. Wonnacott S, Barik J. Nicotinic Ach receptors . *TOCRIS Reviews* 2007; No.28; 1-20.
20. Singh S. Chemistry, design, SAR of cocaine analogs. *Chem Rev* 2000; 100: 925-1024.
21. Wick H. *Pharmakologie des Buscopan*. *Arch exp.pathol Pharmakol*. 1951: 213; 485.

22. Gyermek L. Quaternary derivatives of benzoyl tropine and benzoyl pseudotropine with anticholinergic and local anesthetic properties. *Nature*; 171:788, 195-196.
23. Zipf HF. Endoanesthesia and new pharmacological means of blocking the sensory receptors. *Deutsch Med Wschr* 1953; 78, 1587-89.
24. Pascual JM, Karlin. Delimiting the binding site for quaternary ammonium lidocaine derivatives in the acetylcholine receptor channel. *J.Gen Physiol* 1998; 112: 611-621.
25. Gyermek L, Nador K. Studies on cholinergic blocking substances III. Neuromuscular blocking tropeines. *Acta Physiol Hung* 1953; 4:159-174.
26. Just O. Belladonnin-bromethylate, a new muscle relaxant. *Anaesthesist* 1953; Oct (5) 170-171.
27. Bovet D, Bovet-Nitti F. (1948) *Medicaments du systeme nerveux vegetative*. Chapter 13. Basel, Karger Publ.
28. Ariens EJ, Van Rossum JM.  $pD_x, pA_x$  and  $pD_x$  values in the analysis of pharmacodynamics. *Arch.int Pharmacodyn* 1957; 110: 275-299.
29. Gyermek: Structure-activity relationships among derivatives of dicarboxylic acid esters of tropine. *Pharmacol Therap* 2002; 96; 1-21.
30. Gyermek L. Development of ultrashort- acting muscle relaxant agents: history, research strategies and challenges. *Med Res Reviews* 2005; 25: 610-654.
31. Gyermek L, Nguyen N and Lee C. Pharmacology of G-1-64, a new nondepolarizing neuromuscular blocking agent with rapid onset and short duration of action. *Acta Anaesth Scand* 1999; 43: 651-657.

32. Gyermek L, Lee C, Cho YM, Nguyen N, Tsai, SK. Pharmacology of TAAC3 a new nondepolarizing neuromuscular blocking agent with rapid onset and ultrashort duration of action. *Anest. Analg.* 2000; 94: 879-888.
33. Interim animal toxicology report on TAAC3 from Organon NV, The Netherlands, 2000.
- 34a). Nador K, Scheiber P, Karpati E et al. Synthese und Pharmakologie von N- stereoisomeren quarteren tropane- verbindungen. *Arzneim. Forsch.* 1987; 37, 1324-1327.
- 34b). Engelhardt A. The pharmacology and toxicology of Atrovent. *Scand J Resp Dis, Suppl.* 1979; 103: 110-115.
35. Haining CG, Johnston RG, Smith JM. The neuromuscular blocking properties of a series of bisquaternary tropeines. *Brit J Pharmacol* 1960; 15: 71-81.
36. Wichura W: Pharmakologische eigenschaften des eckains und einiger homotropine. *Z Exp Pathol Ther* 1919; 20: 1-13.
37. Doda M, Gyorgy L, Nador K. Uber die Pharmakologie von N- aethyl-nor- tropeinen. *Arch Int Pharmacodyn Ther* 1963;145: 264- 275.
38. Gyorgy L, Pfeifer K, Doda M, et al. Pharmacology of new tropine ethers with central activity. *Arzneim Forsch* 1968; 18: 517-524.
39. Villa S, Barlocco D, Cignarella G. et al. 3,8-diazabicyclo-[3.2.1]-octane derivatives as analogues of ambasilide, a class III antiarrhythmic agent. *Eur J Med Chem* 2001; 36: 495-506.
40. Cignarella G, Ocelli E, Cristiani G, et al. Bicyclic homologs of piperazine. VI Synthesis and analgesic activity of 3 substituted 8-propionyl-3,8-diazabicyclo[3.2.1] octanes. *J Med Chem* 1963; 6: 764- 766.

41. Barlocco D, Cignarella G, Tondi D. et al. Mono and disubstituted-3,8 diazabicyclo[3.2.1] octane derivatives as analgesics structurally related to epibatidine: Synthesis, activity and modeling. *J Med Chem* 1998; 41: 674-681.
42. BadioB , Saily J. Epibatidine, a potent analgetic and nicotinic stimulant. *Mol Pharmacol* 1994; 46: 563-569.
43. Gyermek , Lee C, Cho YM et al. Quaternary derivatives of granatanol diesters; potent, ultrashort acting nondepolarizing muscle relaxants. *Life Sci* 2006; 79: 559-569.
44. Fozard JR. (1989) The development and early clinical evaluation of selective 5-HT<sub>3</sub> receptor antagonists. Chapter 15 pp. 354-376. In Fozard JR (Ed) *The peripheral actions of 5-hydroxytryptamine*. New York: Oxford. Med. Publ.
45. Doda M, Gyorgy L, Nador K. Adrenergic neurone blocking tropine derivatives with long lasting hypotensive action. *Nature* 1962; 195: 1108-1109.
46. Doda M, Molnar J, Gyorgy L et al. Pharmacological analysis of adrenergic neurone blocking granatane derivatives. *Acta Physiol Hung*. 1967; 31: 257 -266.
47. Gyorgy L, Doda M, Nador K. The significance of quaternary groups of various configurations for the parasympathetic and ganglionic- blocking effect of tropeines. *Arzneim Forsch* 1961; 11: 444-448.
48. Nador K, Gyorgy L, Doda M. Stereoisomeric analogues of Gastropin (4-biphenyl-methyl-3-alpha-tropeiloxo tropanium bromide) *Acta Physiol Hung* 1961; 19: 219 -224.
49. Pfeiffer C. Nature and spatial relationship of the prosthetic chemical groups required for maximal muscarinic action. *Science* 1948; 107: 94-96.